

*Top Reliability, Smart Design,
Valuable Product and Better Life*

FLAMELESS EXPLOSION VENTING DEVICES

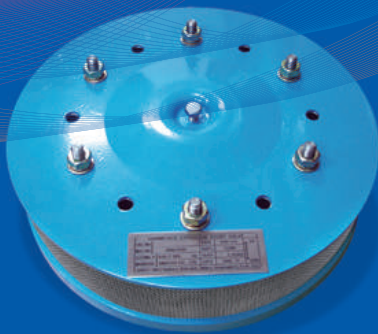

N-ERV

FOR LOW PRESSURE AND
TEMPERATURE SERVICES



EVDM

FOR INLET/EXHAUST MANIFOLD
OF DF OR GAS ENGINES

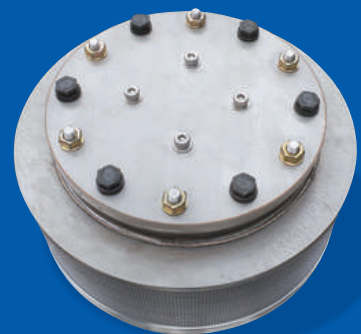

EVDD

FOR EXHAUST DUCT
OF DF OR GAS ENGINES

N-ERV/EVDM/EVDD/MDCS Series

PROSAVE

N-ERV SERIES

(CRANKCASE EXPLOSION RELIEF VALVE)

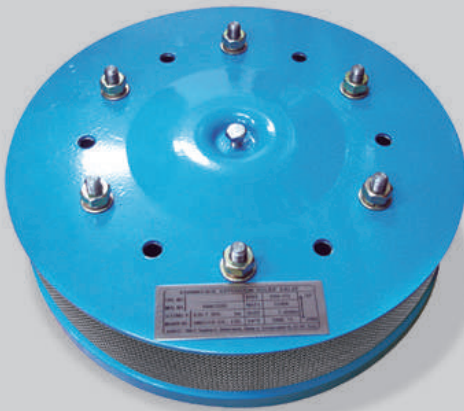

Special benefits of PROSAVE's relief valves

- Quick opening and fully relieving pressure.
- Responds and opening even at a very low pressure setting
- No flame escape to outside.
- Due to absolute tightness after opening and closing, it prevents from secondary explosion.
- Can be installed in all mounting position from vertical to horizontal.
- It is light weight and small volume for easy installation and maintenance.
- Free area of flame arrester is enough wide and similar relief area.
- Closes and seals immediately after an explosion.

Rule and QC Specification being applied

IACS

- IACS UR M66 Type testing procedure for Crankcase Relief Valve
- IACS UR M9 Crankcase Explosion Relief Valves for crankcase of internal combustion engines
- IACS UR M10 Protection of internal combustion engines against crankcase explosion

MAN Diesel Quality Specification

- Quality Specification No. 0742838-0 (Crankcase Relief Valve)
- Production Specification No. 0742839-2 (Function Test of Relief Valve)
- Quality Control No. 0742827-2 (Control of Sub-suppliers)

Safety is our top priority at PROSAVE

PROSAVE's quality assurance system complies with the latest ISO 9001 provision. PROSAVE explosion relief valves have received top mark in numerous explosion tests conducted by the FTZU institute and type approved by DNVGL, KR, LR, ABS, CCS, RS, BV, NK, RINA and MAN-ES.



N-ERV SERIES

(CRANKCASE EXPLOSION RELIEF VALVE)

Materials of Construction

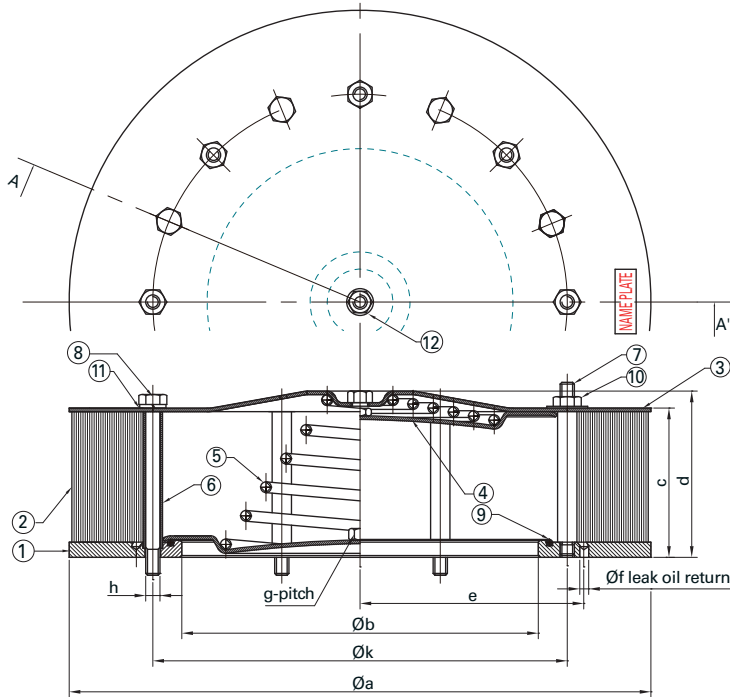

No.	DESCRIPTION	MATERIAL	Q'TY
1	BASE FLANGE	SS400	1
2	ELEMENT	PROPERTY	1
3	COVER	SS400	1
4	DISC	SS400	1
5	SPRING	PROPERTY	1
6	PIPE	SUS304	-
7	STUD BOLT	SS400	-
8	HEX BOLT	8.8	-
9	O-RING	NBR	1
10	NUT	SS400	-
11	WASHER	SS400	-

Dimension Table & Field Information

Model	Geom. Relief Area (cm ²)	Dimension				Leak Oil Return		Connection		
		a (mm)	b (mm)	c (mm)	d (mm)	e (mm)	f (mm)	No. of Bolts	h Thread	k p.c.d (mm)
N-ERV-98	59.4	200	87	49	49	75	8	4	M8 or 1/4"	122
N-ERV-122	95	232	110	53.5	61.5	86.5	8	6	M10 or 3/8"	150
N-ERV-162	177	272	150	72.5	79.5	110	8	6	M10 or 3/8"	190.5
N-ERV-173	201	285	160	78	84	115	8	6	M10 or 3/8"	203
N-ERV-204	284	312	190	92	102.5	128	8	6	M10 or 3/8"	230
N-ERV-224	346	341	210	96	103.5	142	8	6	M12 or 1/2"	255
N-ERV-266	499	390	252	112.5	126	170	10	6	M12 or 1/2"	302
N-ERV-320	732	489	305	133	146	197.5	10	6	M12 or 1/2"	355
N-ERV-345	829	528	325	136	148	214	10	6	M16 or 5/8"	290
N-ERV-420	1260	604	400	166	185	251	12	8	M16 or 5/8"	465
N-ERV-480	1165	672	460	190	211	287	12	8	M16 or 5/8"	530
N-ERV-565	233	757	541	221	240	335	12	12	M16 or 5/8"	615
N-ERV-645	2990	842	671	249	268	378	12	12	M16 or 5/8"	700
N-ERV-735	3905	937	705	279	318	425	12	12	M16 or 5/8"	795

EVDM/EVDD SERIES

(EXPLOSION RELIEF VALVES FOR INLET/EXHAUST MANIFOLD AND EXHAUST DUCT SERVICES)

To avoid a dangerous pressure rise and resultant damage when an explosion occurring in exhausts and inlet manifold. It is necessary to provide pressure relief valves of an enough relief area. This valve is suitable for high temperature applications up to 700°C and high pressure up to 6 barg.

EVDM SERIES

FOR INLET/EXHAUST MANIFOLD
OF DF OR GAS ENGINES

General

EVDM Series is mounted on the inlet manifold of the DF ENGINE or GAS ENGINE. If the explosion occurs during the movement of the gaseous fuel from the inlet manifold to the inside of the cylinder, explosion pressure can be discharged, and flame can be blocked and automatically distinguished by flame arrester element for prevention of the man and important facilities.

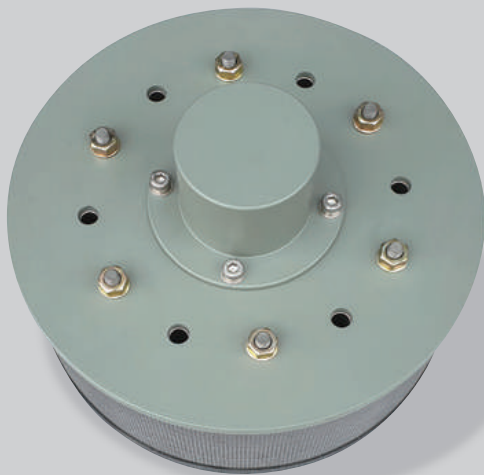

EVDD SERIES

FOR EXHAUST DUCT
OF DF OR GAS ENGINES

General

EVDD Series is mounted on the exhaust duct of DF ENGINE or GAS ENGINE. When an explosion occurs by unburned gas fuel in the exhaust lines, explosion pressure can be discharged by EVDD, and flame can be blocked and automatically distinguished by flame arrester element for prevention of the man and important facilities.

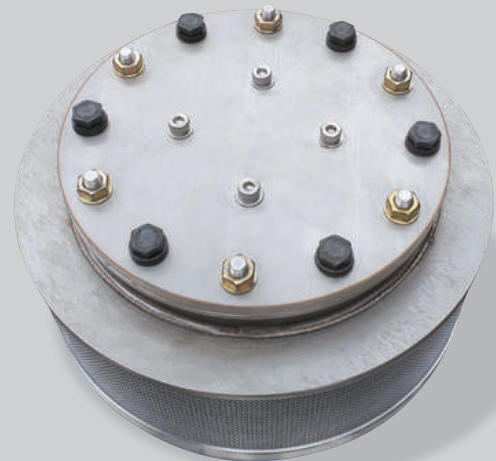

International patent pending

EVDM/EVDD SERIES

(EXPLOSION RELIEF VALVES FOR INLET/EXHAUST MANIFOLD AND EXHAUST DUCT SERVICES)

Key Advantage

- Automatic re-closing structures against rupture disc (non re-closing devices)
- No need engine shut-down.
- Very high capability seat tightness.
- Available continuously engine operation.
- Prevention of secondary explosion.
- Protection of man and key components due to explosion.
- Discharging protection of unfired and/or burned mist, gas, ashes and dust, into engine.
- Protection devices for Health, Safety and Environment.
- Available IoT options

Explosion Simulation and Analysis

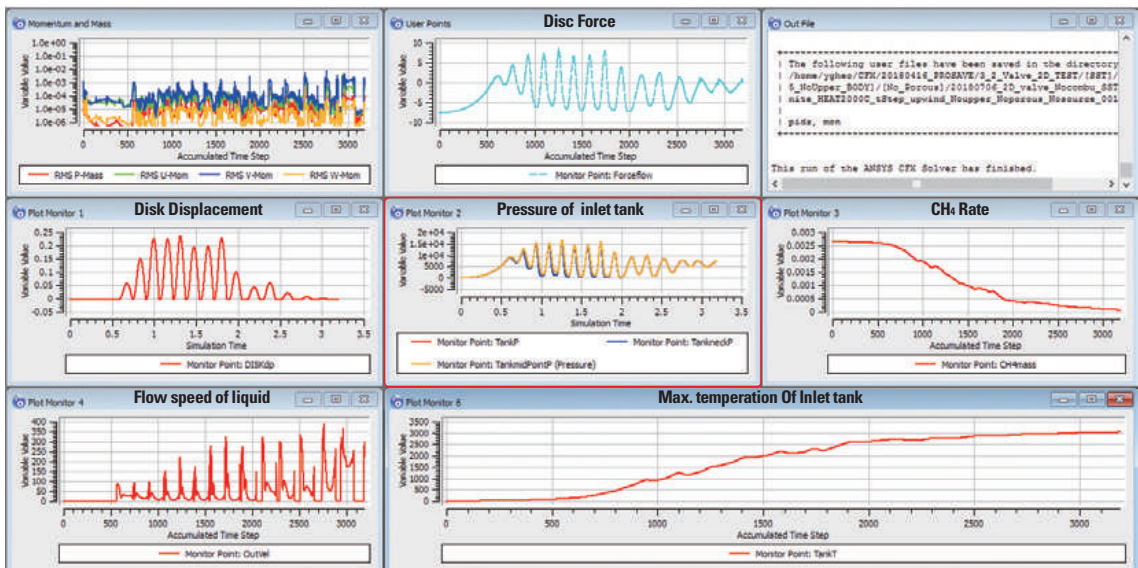
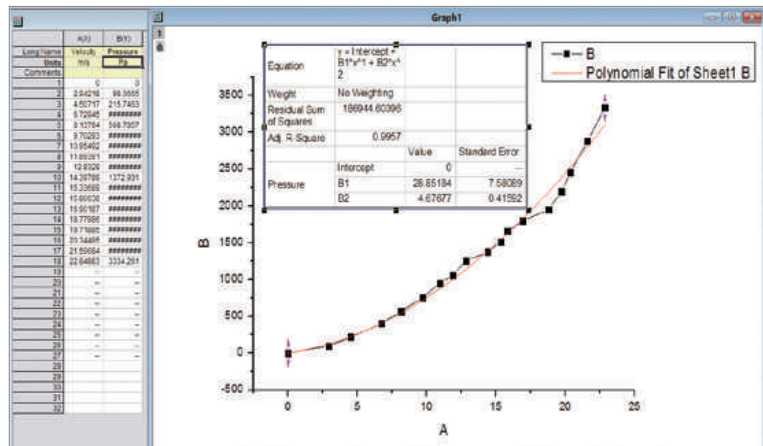
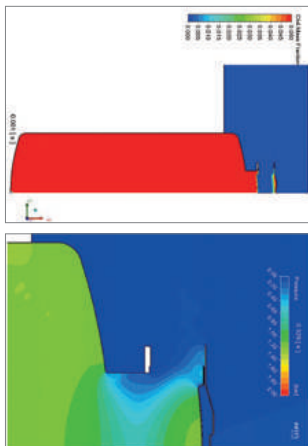

EVDM/EVDD SERIES

(EXPLOSION RELIEF VALVES FOR INLET/EXHAUST MANIFOLD AND EXHAUST DUCT SERVICES)

EVDM SERIES

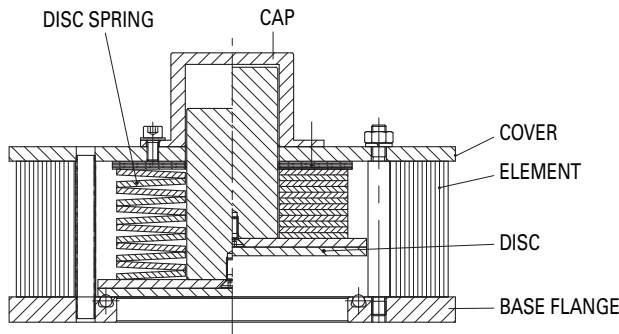

EVDD SERIES

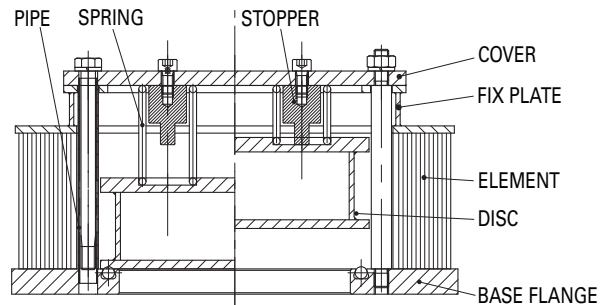

EVDM : INLET/EXHAUST MANIFOLD OF DUAL-FUEL OR GAS ENGINES

ITEM	Geom. Relief Area (cm ²)	Out dia. (mm)	Hex. bolt	B.C.D (mm)	Opening Pressure (bar)			
					Temp. <100°C		Temp. <700°C	
					Min.	Max.	Min.	Max.
EVDM-98	59.4	227	4-M10	122	3.8	6.5	3.8	6.5
EVDM-122	95	256	6-M10	150				
EVDM-162	177	476	6-M10	190.5				
EVDM-173	201	309	6-M10	203				
EVDM-204	284	436	6-M12	230				
EVDM-224	346	374	6-M16	255				
EVDM-266	499	417	8-M16	302				

※ The opening pressure may vary depending on the user and application.

EVDD : EXHAUST DUCT OF DUAL-FUEL OR GAS ENGINES

ITEM	Geom. Relief Area (cm ²)	Out dia. (mm)	Hex. bolt	B.C.D (mm)	Temp.	Opening Pressure (bar)	
						Min.	Max.
EVDD-173	201	309	6-M10	203	<700°C	0.15	0.22
EVDD-204	284	436	6-M12	230			
EVDD-224	346	374	6-M16	255			
EVDD-266	499	417	8-M16	302			
EVDD-320	732	466	6-M12	355			
EVDD-345	829	530	6-M12	390			
EVDD-420	1260	581	8-M16	465			
EVDD-480	1665	680	8-M16	530			
EVDD-565	2300	733	12-M16	615			
EVDD-645	2990	847	12-M16	700			
EVDD-735	3905	911	12-M16	795			

※ The opening pressure may vary depending on the user and application.

MDCS SERIES

(MICRO DUST COLLECTING SYSTEM AND FLAMELESS EXPLOSION VENTING DEVICES)

MDCS-P SERIES

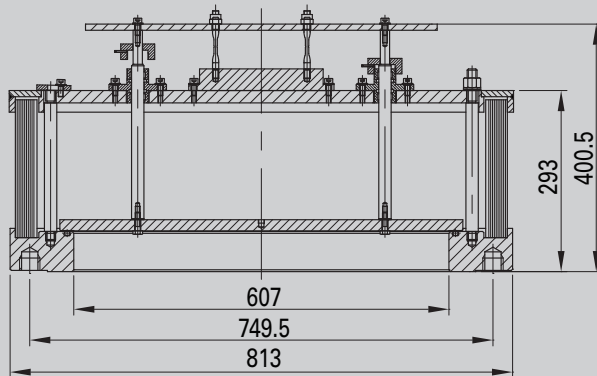

MDCS-S SERIES

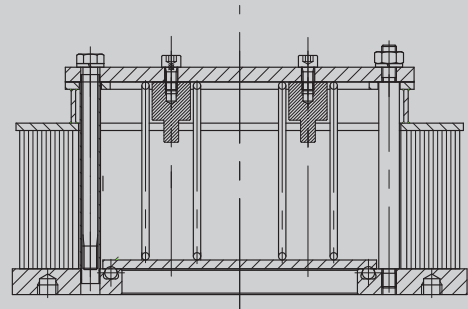

Conventional explosion venting device	PROSAVE's innovative explosion venting devices
Explosion panel, rupture disc with or without wire mesh filter	Flameless explosion venting valve with relieving disc and automatic re-closing spring
Non re-closing type	Automatic re-closing type
Non re-usable	Re-usable
Every time required spare	No need spare
Dangerous flame is exhausted to outside	Prevention of exhausting flame, flammable gas, vapor, mist or dust
Damage man and equipment	Protection of human and other key systems

Additional function of PROSAVE's relief vales

Suitable for use in tanks, silos, conveyors and applications where explosion hazards exist due to the dust explosions, processing handling and storage of pulverized material.

PROSAVE's explosion relief valves are customer designed to the specific application for safety.



**TOP RELIABILITY OF SAFETY & ENVIRONMENT IS THE FIRST
& MOST IMPORTANT**



Products

- Air Release Valves
- Combination Air Release and Air/Vacuum Valve
- Vacuum Breaker Valves
- Pilot Operating Pressure/ Vacuum Valves
- Surge Relief Valves
- Crankcase Explosion Relief Valve
- Explosion Venting Devices
- High Velocity Pressure/ Vacuum Valve
- Flame Arrester
- Flame Screen
- Gas Free Cover
- Pressure/Vacuum Relief Valve (Breather Valves)
- Solar Still [HMED/SMED]

Application Fields

- Offshore & Ocean Gas Plants
- Desalination Plants
- Ballast System for Ships & Offshore Plants
- Sea & Fresh Water Plants
- Marine Tank Ships
- Cryogenic gas Facilities
- Petrochemical Plants
- Tank Terminals
- Marine Engines
- Generators
- Duct

ISO9001 / ISO14001 Registered

PROSAVE CO., LTD.

115-22, Tekeunobaelli 1-ro, Jillye-myeon, Gimhae-si,
Gyeongsangnam-do 50875, Korea
TEL. +82 (0)55 313 3510~1 FAX. +82 (0)55 313 3512
E-mail: prosave@prosave.co.kr www.prosave.co.kr



MED(CE)



ISO 9001/14001



Service station (Agent / Distributor)

This document is distributed for informational purposes only.
It is not to be construed as creating or becoming part of any PROSAVE
contractual or warranty obligation unless expressly stated in a written sales contract.
PROSAVE CO., LTD. All Rights Reserved (2018.09.03)